

Multi-angle Low Cost ultrasound Camera for Aircraft NDT

November 8, 2005

Bob Lasser, Marvin Lasser, Jack Gurney, Dave Rich, John Kula

Imperium, Inc.

Silver Spring, MD

Agenda

- Introduce Imperium, Inc.
- Acoustocam Technology Overview
- Review longitudinal wave results
- Review shear wave results
- Large area scanning results
- Future developments

Imperium, Inc.

- Headquarters outside Washington, DC
- Began 1996 by Dr. Marvin Lasser, Chairman
- Focus solely on novel ultrasound imaging technology
- First sales in 1999
- First reseller agreement in 2000
- Three U.S. patents granted, others pending
- Handheld unit developed: 2003
- 10 employees

Digital Acoustic Video (DAV™)

- Ultrasound camera
- Real time, C-scan imaging
- Non-specialized user
- Standard video output

Digital Acoustic Video (DAV™)

- Same “rules” of imaging as conventional ultrasound
- Two-dimensional array
- Lens based
- Broadband

Ultrasound Camera Technology

Digital Acoustic Video (DAV™): Imaging Array

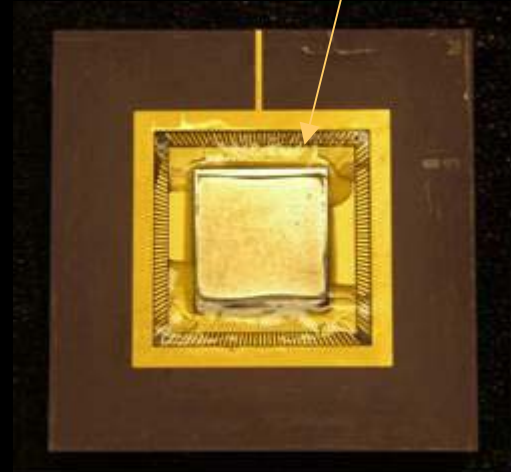
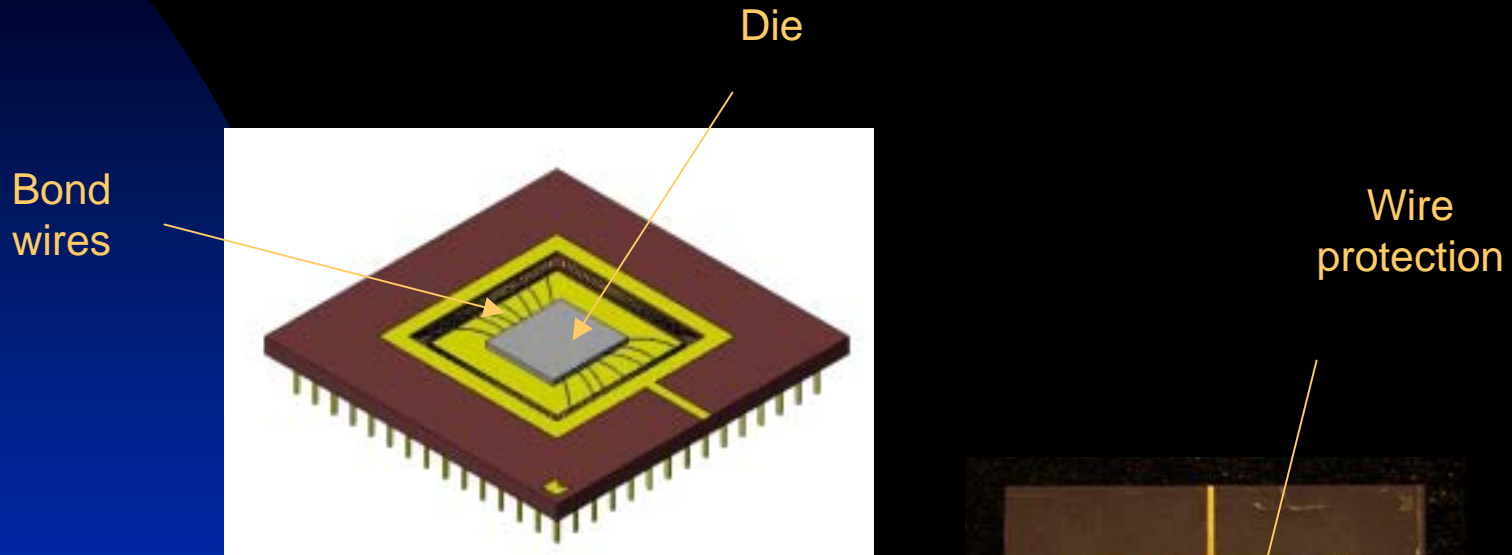

- Custom design
- $120 \times 120 = 14,400$ elements
- Piezoelectric material deposited

Two-Dimensional Array

- Hybrid: Piezoelectric material deposited on silicon readout chip via semiconductor processing

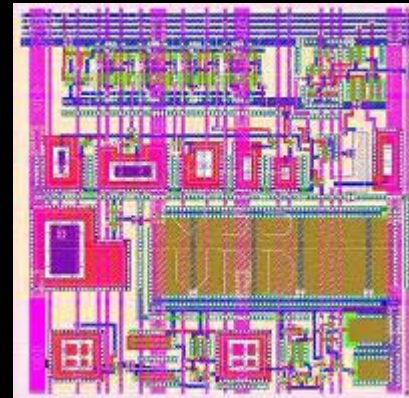
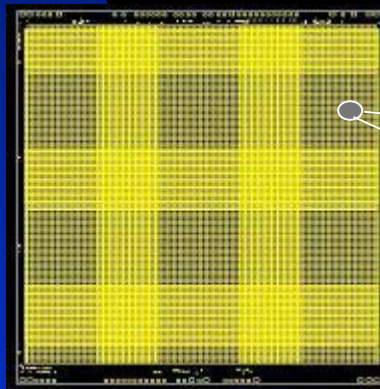

Piezo



Pre-amp



Detection



Filtering/ UC



MUX

Pre-amplifier Array Response

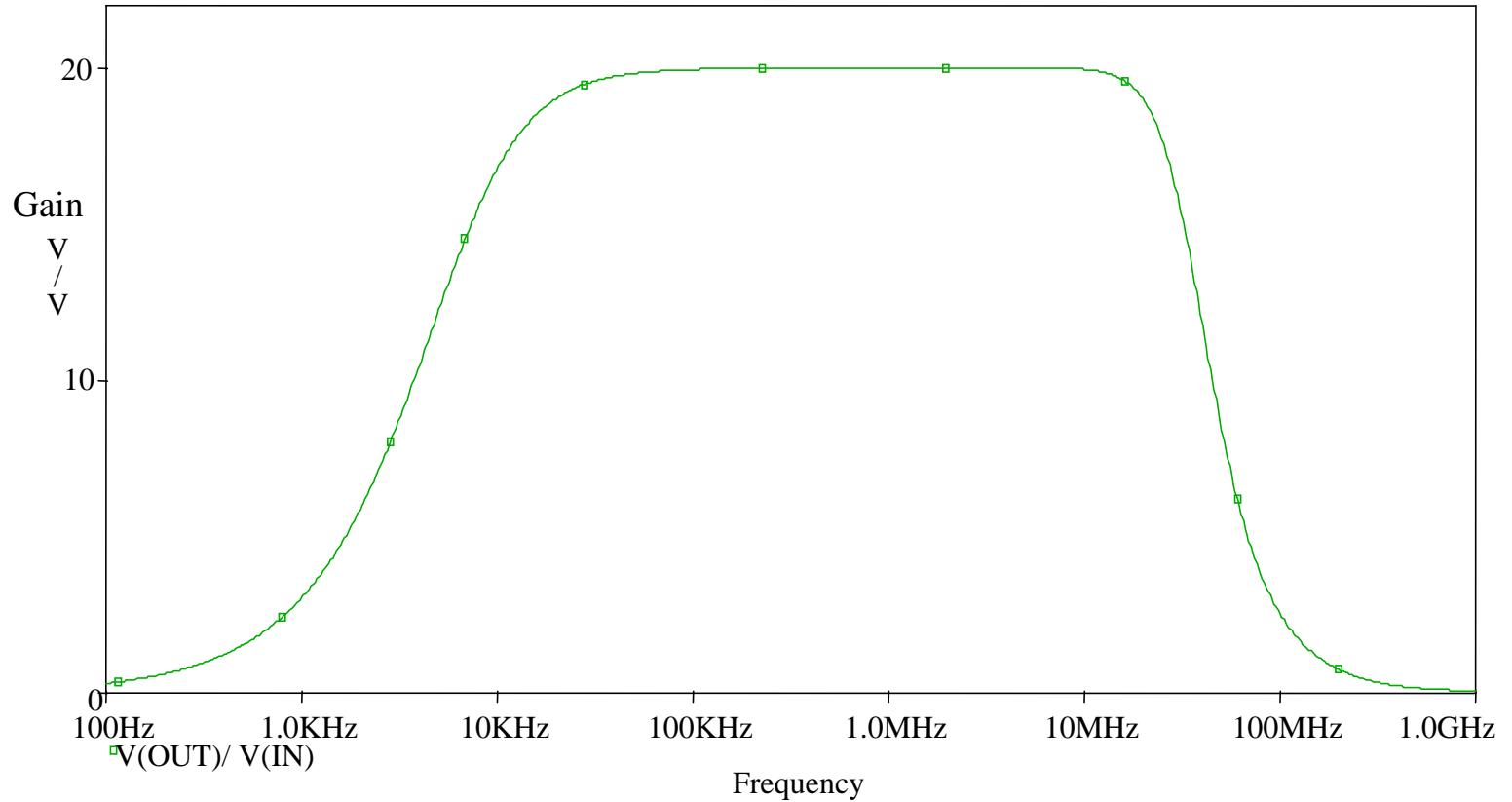

Acoustic Lens

- Zero-power beamformer
- Adjustable focus
- Adjustable zoom

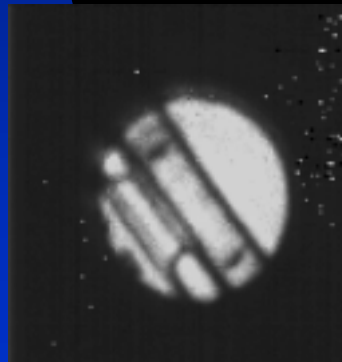

No magnification

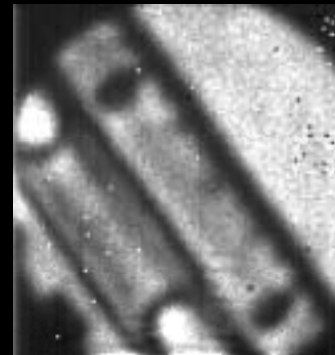

With magnification

DAV versus conventional UT

$120 \times 120 = 14,400$

Point by point
technology
captures 1 point
per snapshot

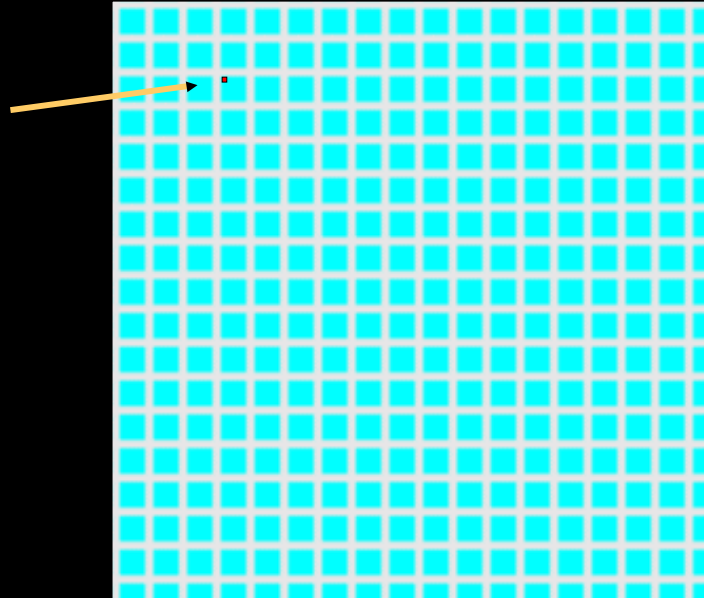

Area coverage
technology
captures 16,384
points per
snapshot.

Through Transmission

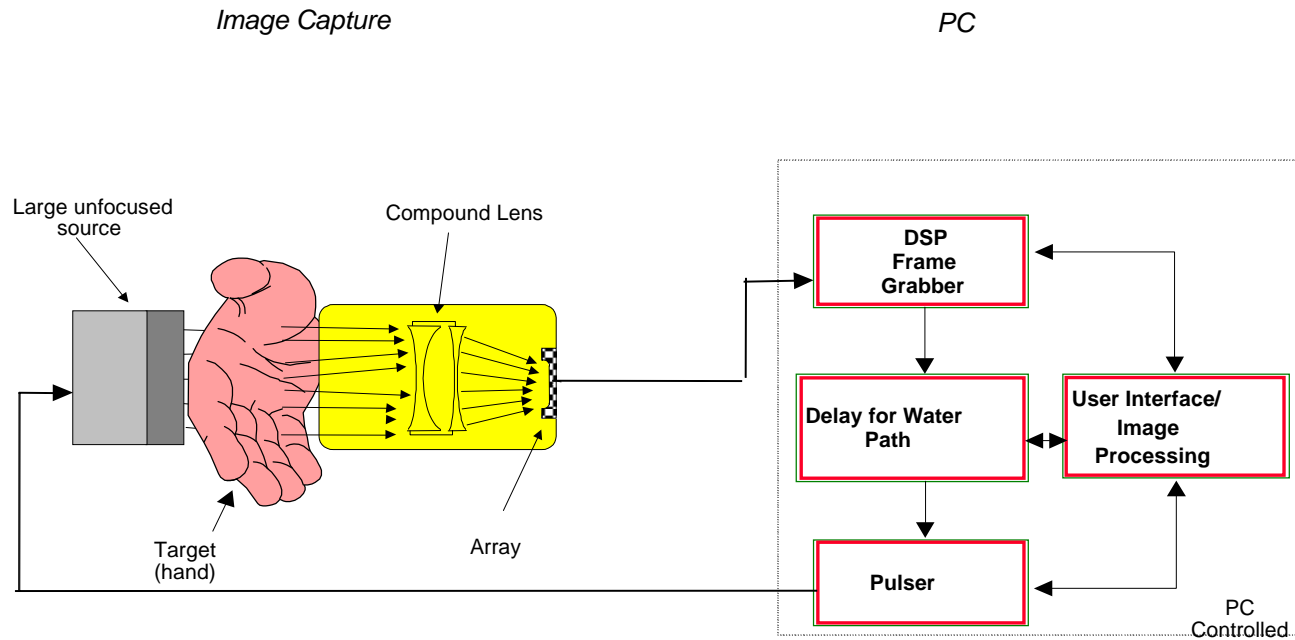

Through Transmission

3 inch Field of View – 3 MHz

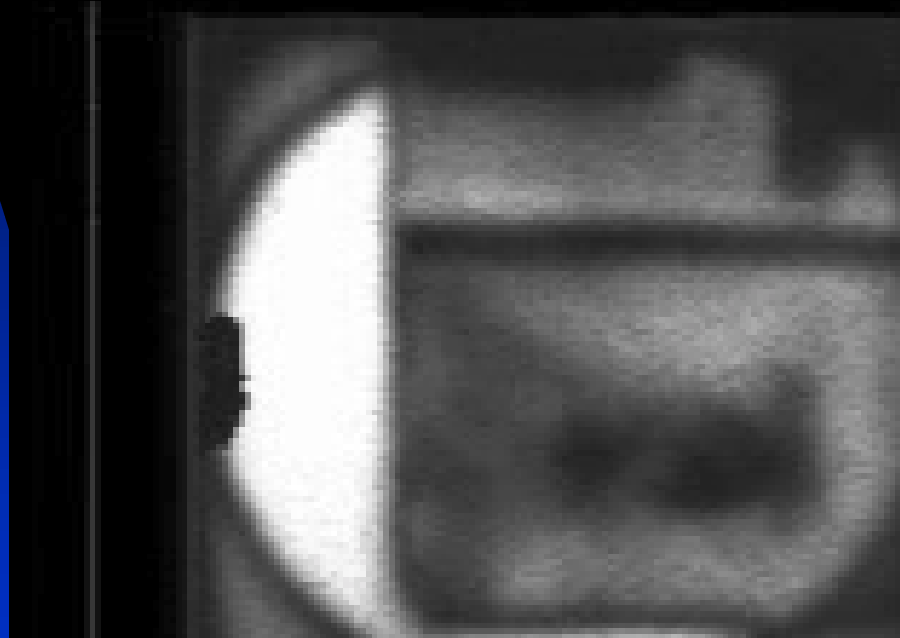

DAVTM Technology - Pulse Echo

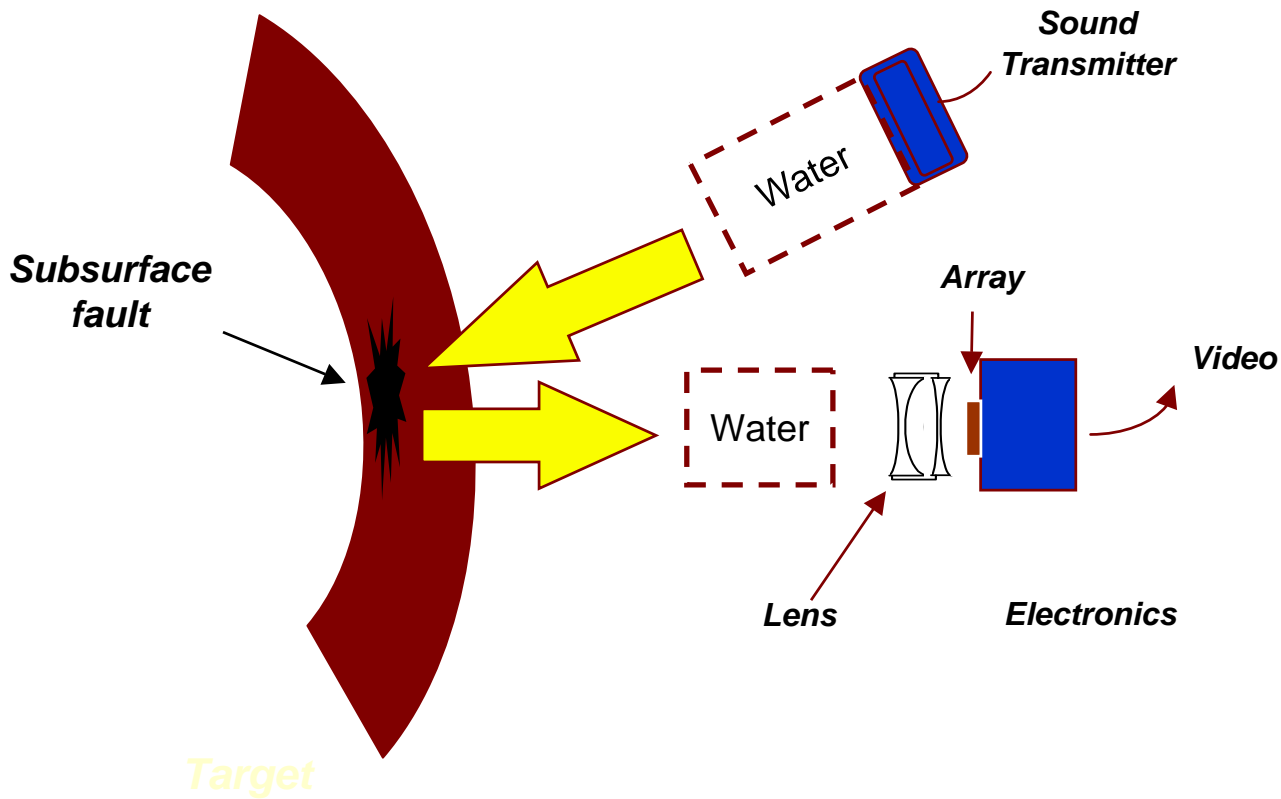

Pulse echo image of quarter

Pulse Echo – 50/50 Beamsplitter

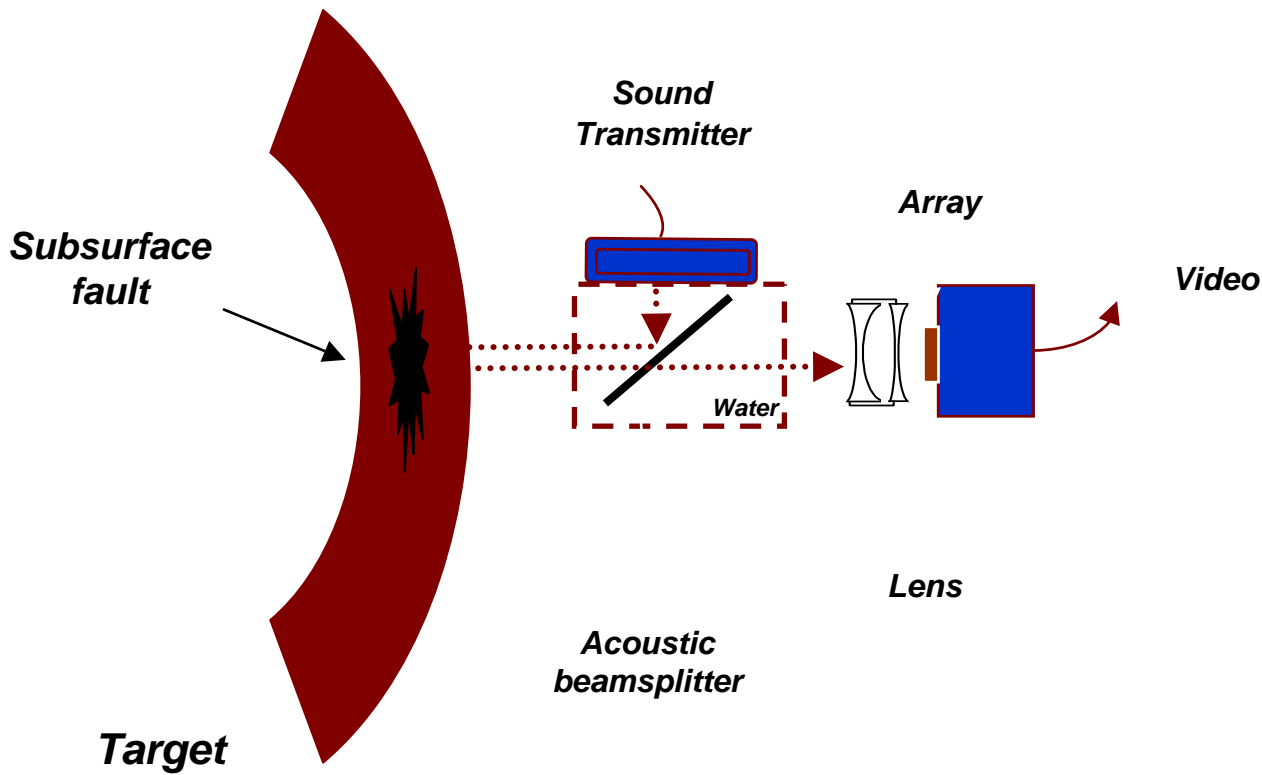

*Pulse echo
image of quarter*

Longitudinal Wave Results: Typical Composite Images

Laminate Composite

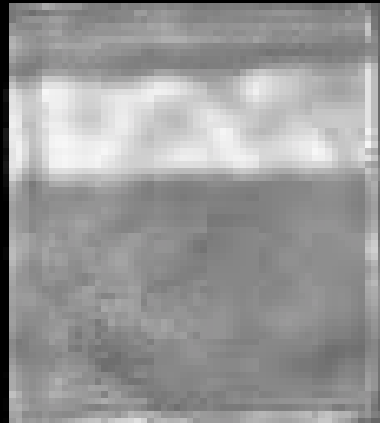

Typical Composite Images

Honeycomb Composite

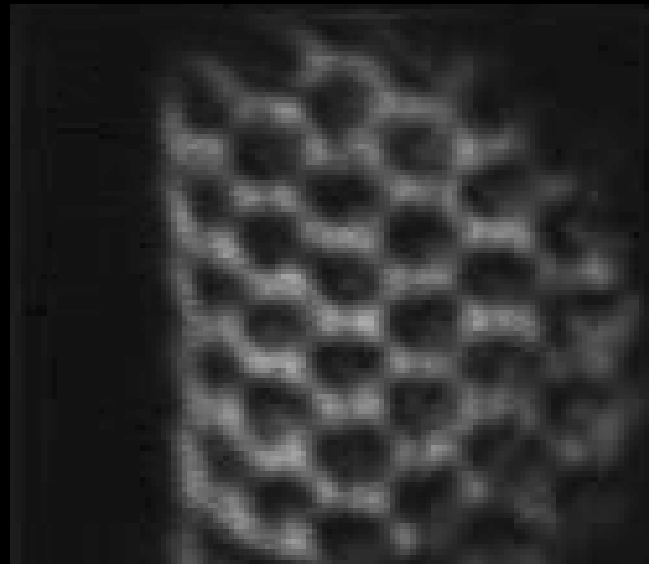

Results: Impact Damage on Solid Laminate Using Handheld Acoustocam

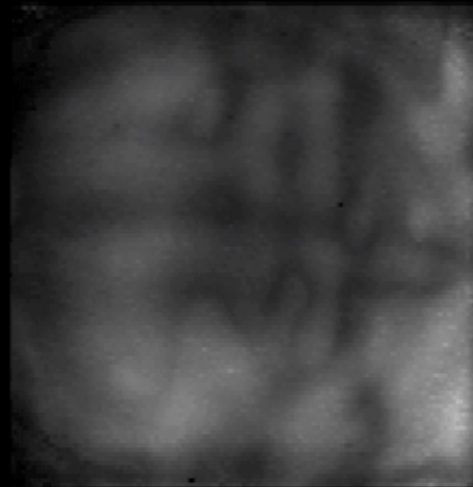

Pulse Echo – Depth (range gating)

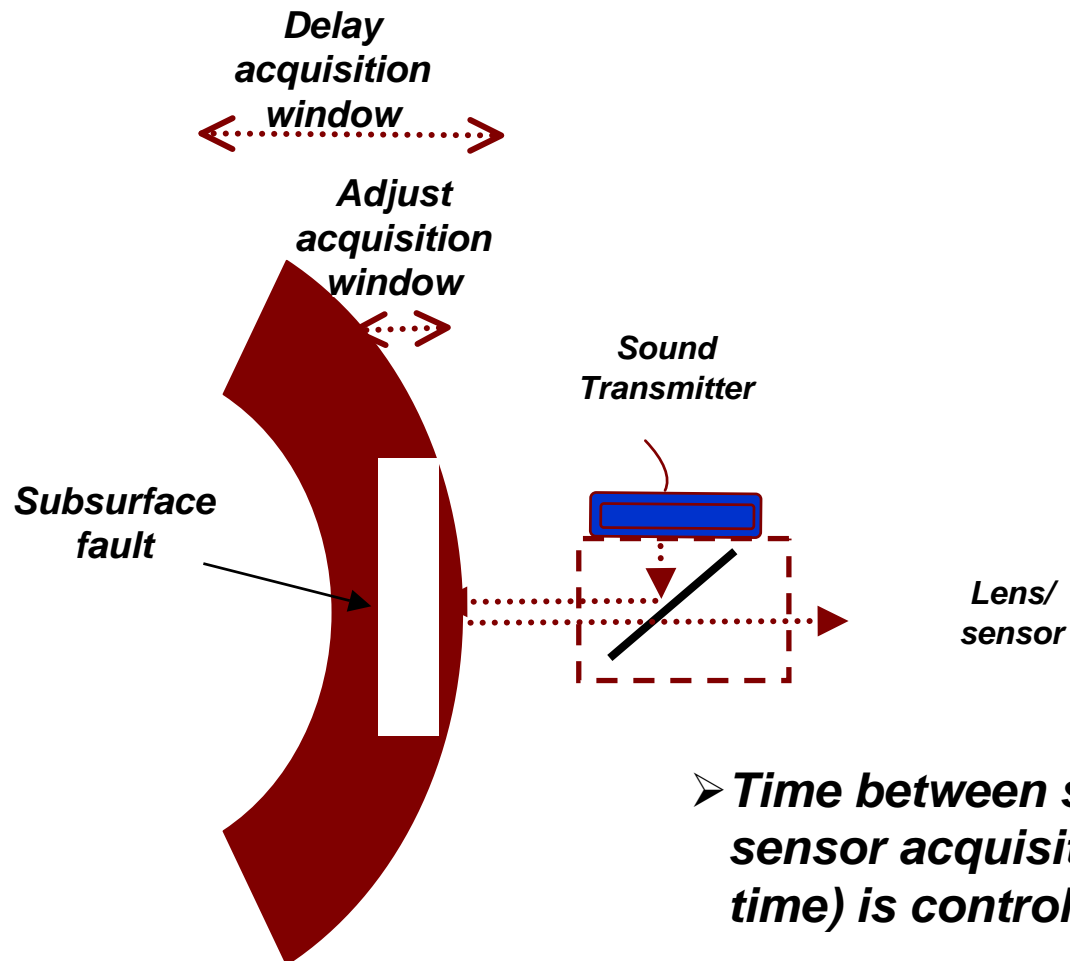

Range Gating for Depth

- Front gate is moved to first eliminate front surface reflection
- Target is then gated through

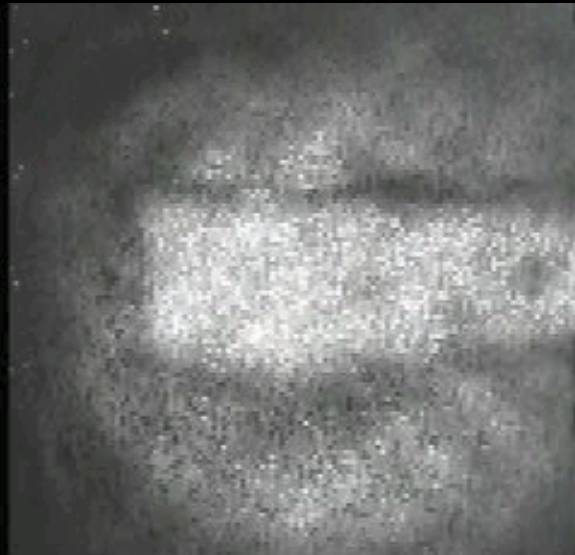

Prototype Development



2002



2003



2004



2005



Production Camera Head

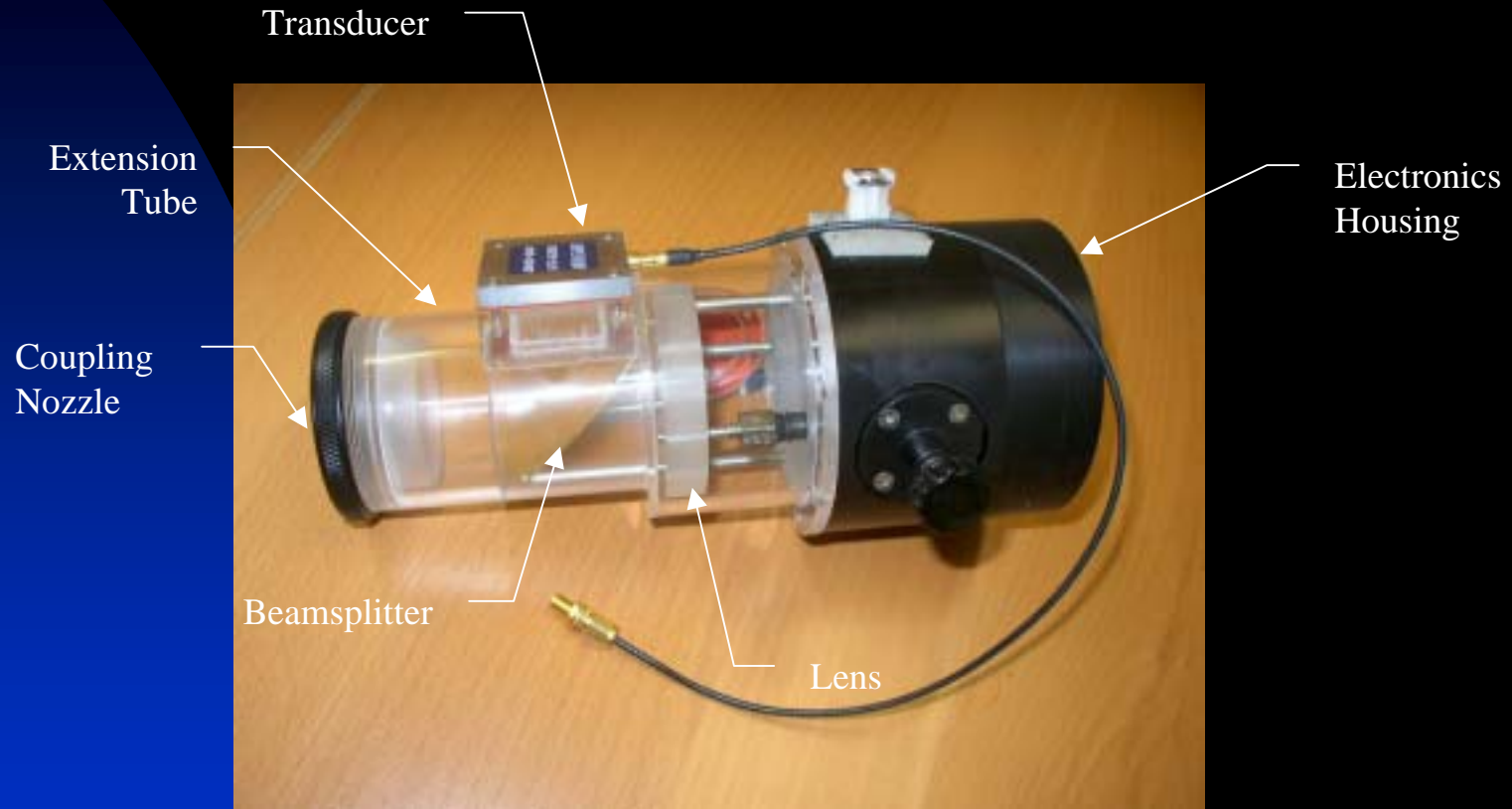

Portable Camera System



Computer

Camera Head

Control Unit

Transducer Replacement



- By removing auxiliary handle alternate transducers may be installed

Graphical User Interface

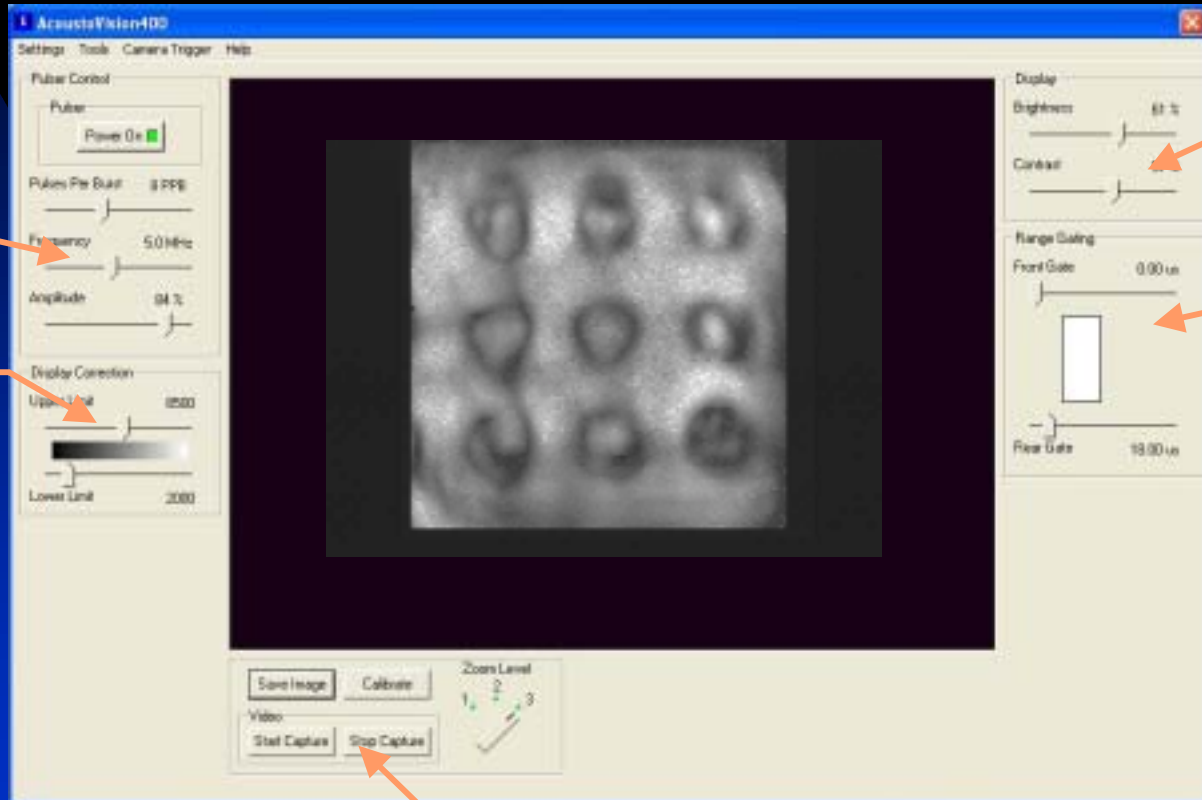

Frequency/ # pulses

Dynamic Range

Brightness/ Contrast

Set imaging depth

Capture images/ video

Shear wave results



Shear Wave Imaging in aluminum

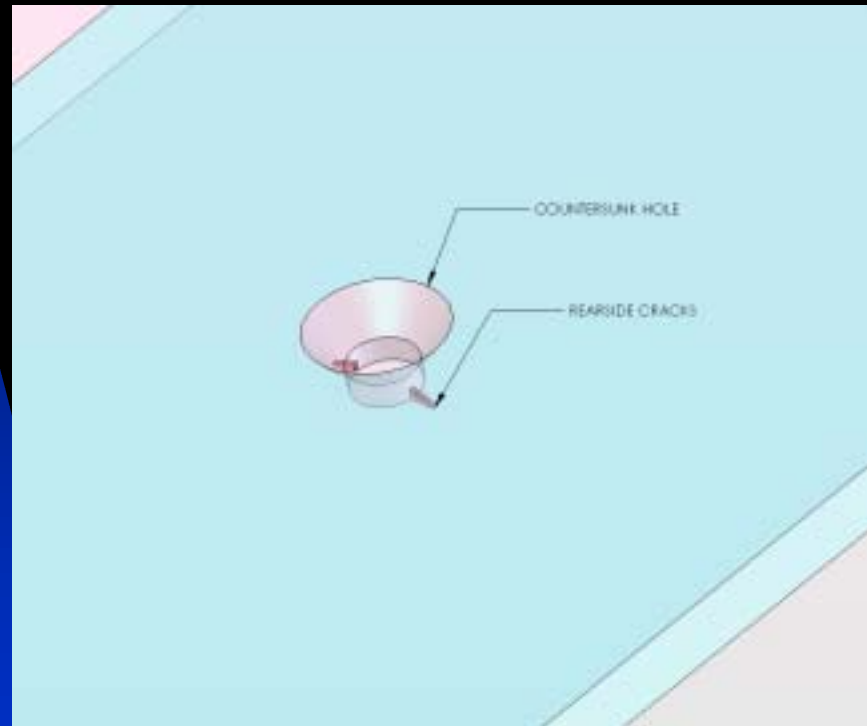

Shear Wave Handheld

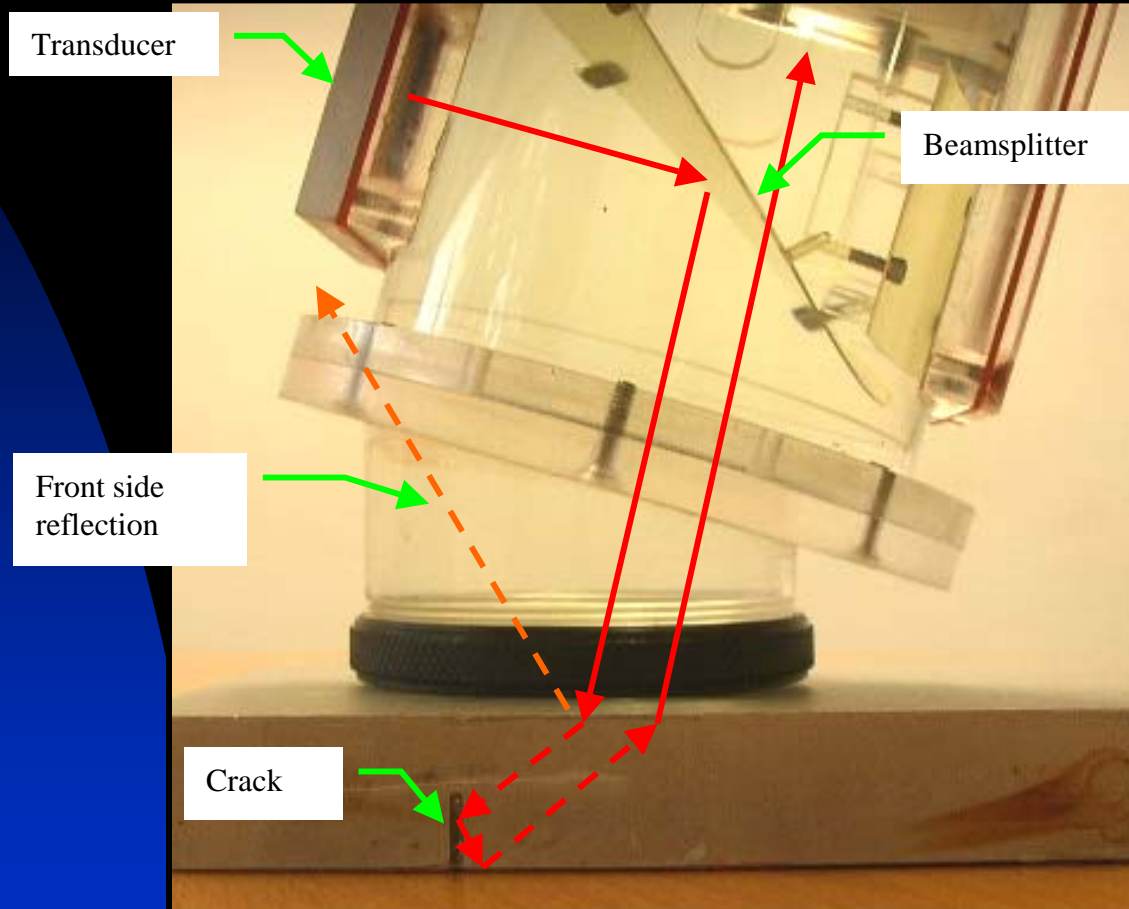

Shear Wave Handheld @ 5 MHz



Side of rivet

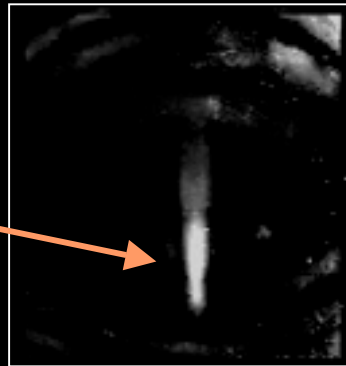

0.080"
Cracks

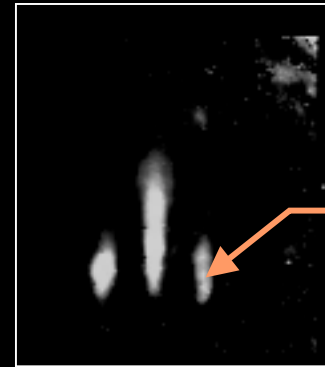

Shear Wave Handheld @ 5 MHz



Large area scanning

Designed to interface with existing scanner



Production Scanning: Bubbler

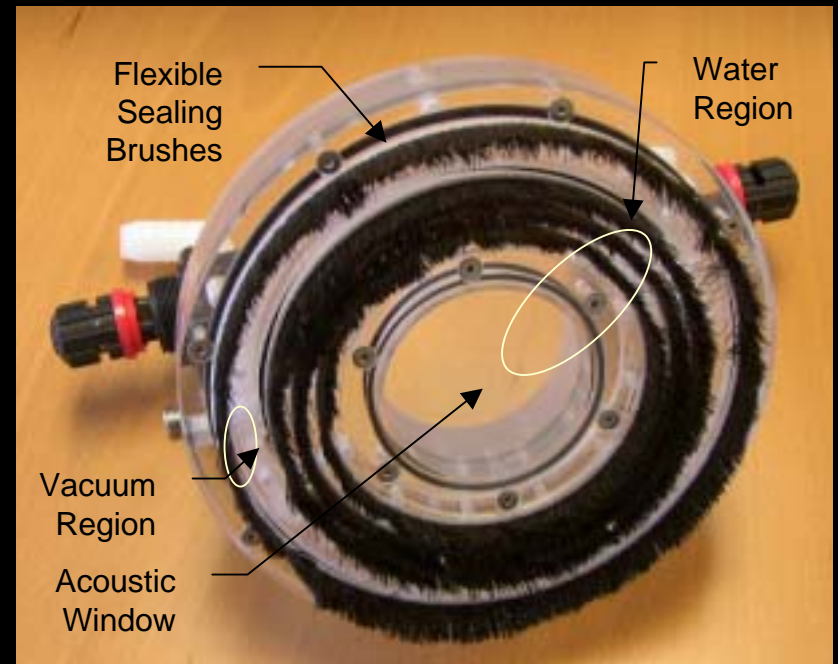
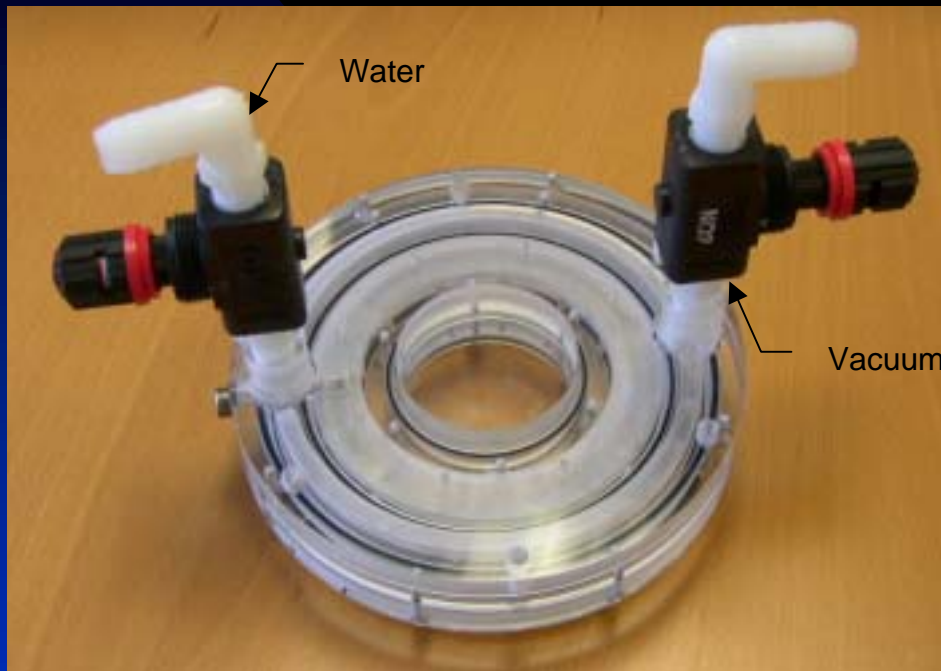

Bubbler fabricated for use with production camera

Production Scanning Results

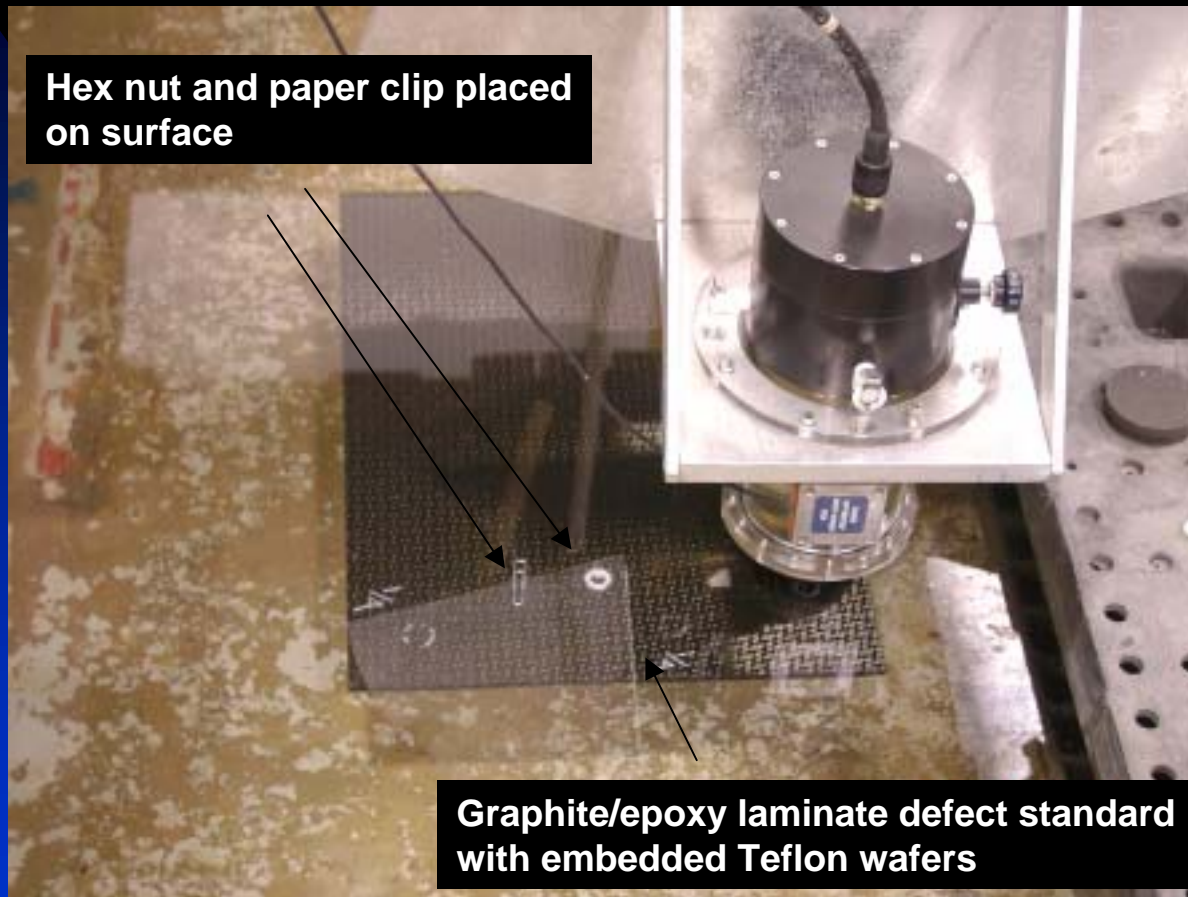

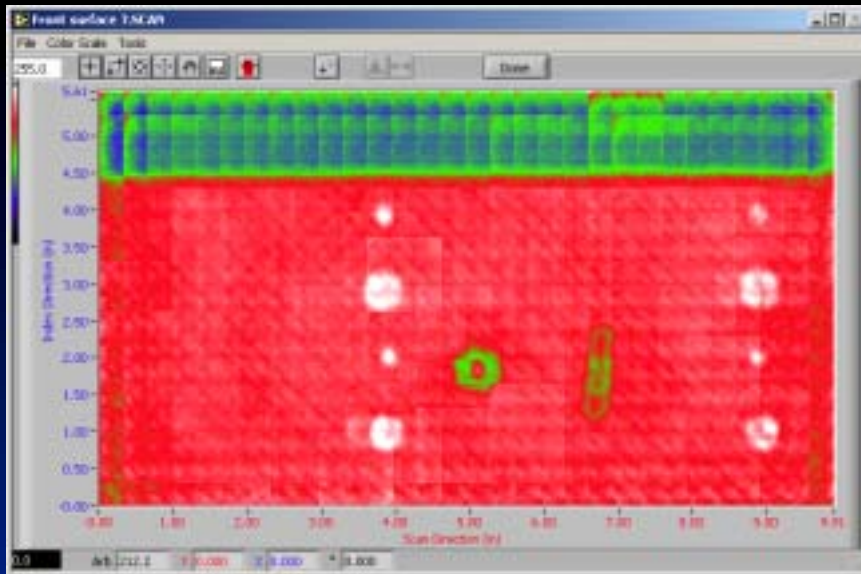

UT camera scan with stitching
algorithm applied
- 0.3" scan increment

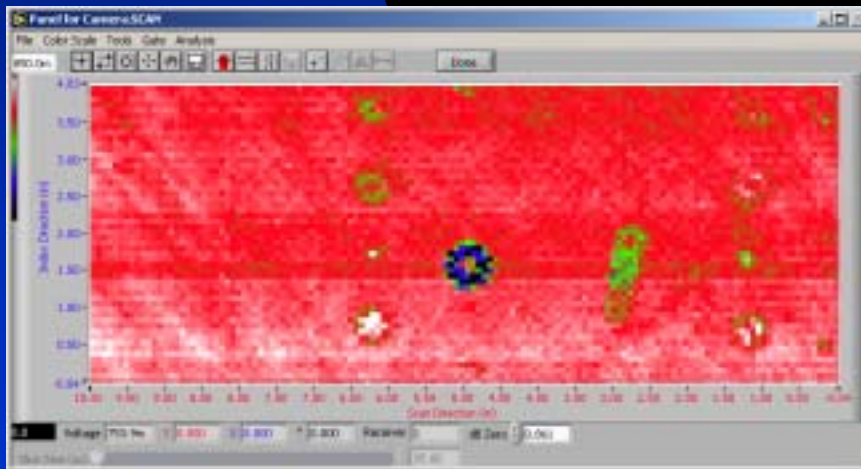

Conventional immersion scan
- 2.25 MHz, 0.25" diameter transducer
- 0.075 scan increment

UT Camera with Bubble Attached



Vertical orientation test

Planned Developments

- Direct digital image download via USB
- Redo board set for handheld
- New imaging array
- A-scan built-in
- User interface development

Integrated A-scan

And receiver

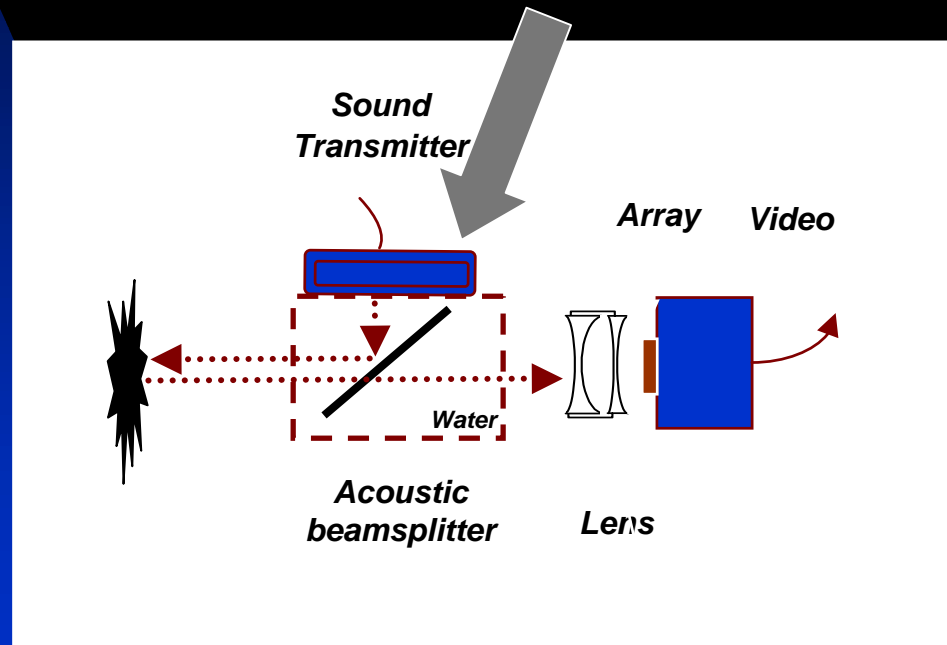

Presentation of Imagery and A-scan

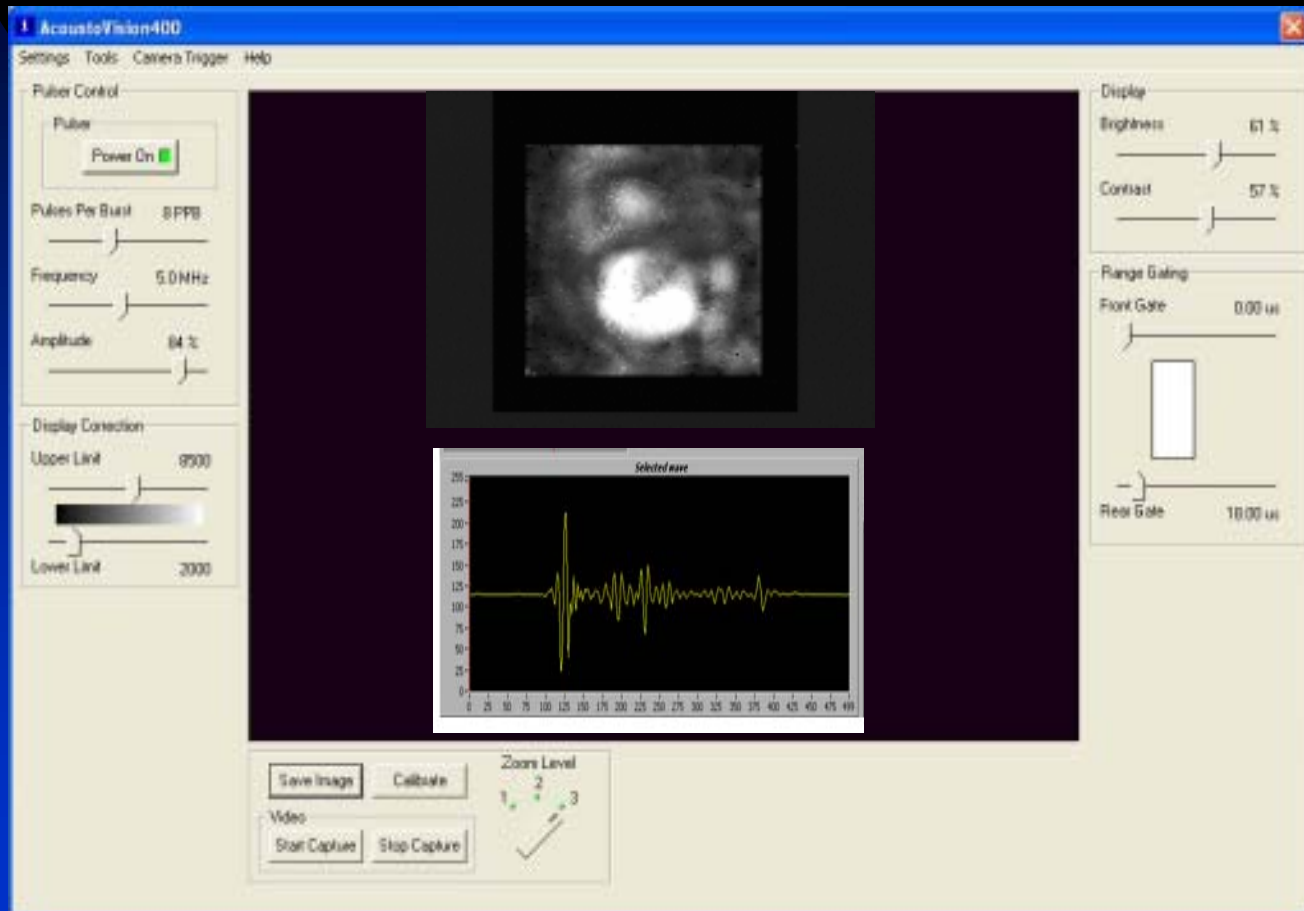

Application Areas

- Metal
 - ◆ Cracking, including under rivet heads
 - ◆ Corrosion
- Composites
 - ◆ Impact damage
 - ◆ Skin to core disbonds
 - ◆ Porosity

Conclusions

- High sensitivity/detectability
- Flexible
- Ease to use
- Video output
- Coupled with quantitative gives 'best of both worlds'